



# Two Wheel Tractors

with PowerSafe® Clutch

MODELS 710 • 728 • 738 • 740



## Operating Instructions

Before commissioning the machine, read operating instructions and observe warning and safety instructions.



# TRACMASTER

Landscape • Groundcare • Conservation

## Contents

<b>Page 3</b>	<b>Safety</b>
<b>Page 4</b>	<b>Controls Diagrams - 710 &amp; 728</b>
<b>Page 5</b>	<b>Controls Diagrams - 738 &amp; 740</b>
<b>Page 6</b>	<b>Controls Description</b>
<b>Page 7</b>	<b>Assembly Instructions</b>
<b>Page 8</b>	<b>How to Start Petrol Engine</b> <b>How to Start Diesel Engine</b>
<b>Page 9</b>	<b>Operation</b> <b>How to Stop Engine</b>
<b>Page 10</b>	<b>Maintenance Guide</b>
<b>Page 11</b>	<b>Maintenance Programme</b>
<b>Page 12</b>	<b>Service Information</b>
<b>Page 14</b>	<b>Troubleshooting Guide</b>
<b>Page 15</b>	<b>Risk Assessment</b>
<b>Page 16</b>	<b>Service Record</b>
<b>Page 17</b>	<b>Warranty Registration</b>

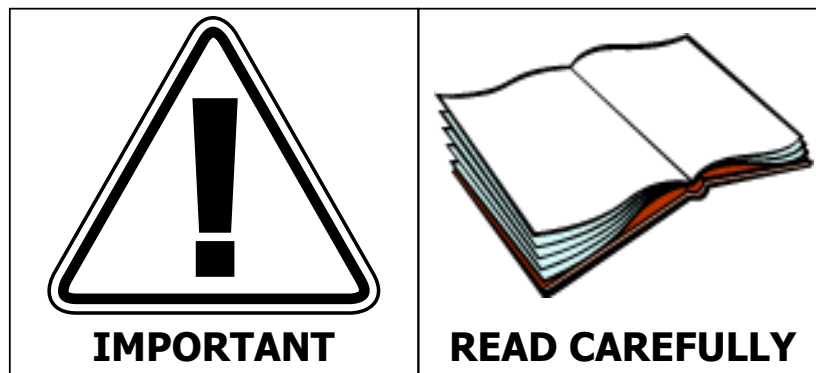

**No liability will be accepted for any damage caused to persons or property through failure to observe the operating and safety instructions.**

## Safety

**ALWAYS** start the engine in the open air

**DO NOT** smoke when refuelling

**DO NOT** mix OIL with the fuel

**ALWAYS** stop the engine before making any adjustments, refuelling, moving or cleaning, or when the unit is unattended

**USE ONLY** fuel from containers designed for this purpose - refuel outdoors only and replace the tank cap securely

**IN CASE** of petrol spillage move the machine away from the area of spillage and allow the petrol vapours to dissipate before starting the engine

**DO NOT** remove any safety guards that are fitted

**DO NOT** touch any moving parts or attempt any maintenance whilst the machine is running - **KEEP HANDS AND FEET AWAY**

**BEFORE** starting work clear the work area of any objects that could damage the machine

**DO NOT** allow children or anyone uninstructed to operate the machine - **KEEP ANIMALS AWAY**

**DO NOT** use on slopes or banks of more than 20°

**ALWAYS** wear suitable clothing to give personal protection including footwear that offers a good grip

**AVOID** wearing loose garments that may catch in moving parts

**KNOW** how to stop the machine in an emergency

**NEVER** interfere with any control settings on the engine

**NEVER** select reverse gear with your back to a wall or other immovable object

**IF A FAULT** develops **DO NOT** attempt any repair - immediately contact the supplier from whom the machine was obtained

**VISUALLY INSPECT** the machine before use - ensure all tines, nuts and bolts are tight and not worn or damaged and replace tines if necessary

**KEEP IN MIND** the operator is responsible for accidents or hazards occurring to people or property

## Controls

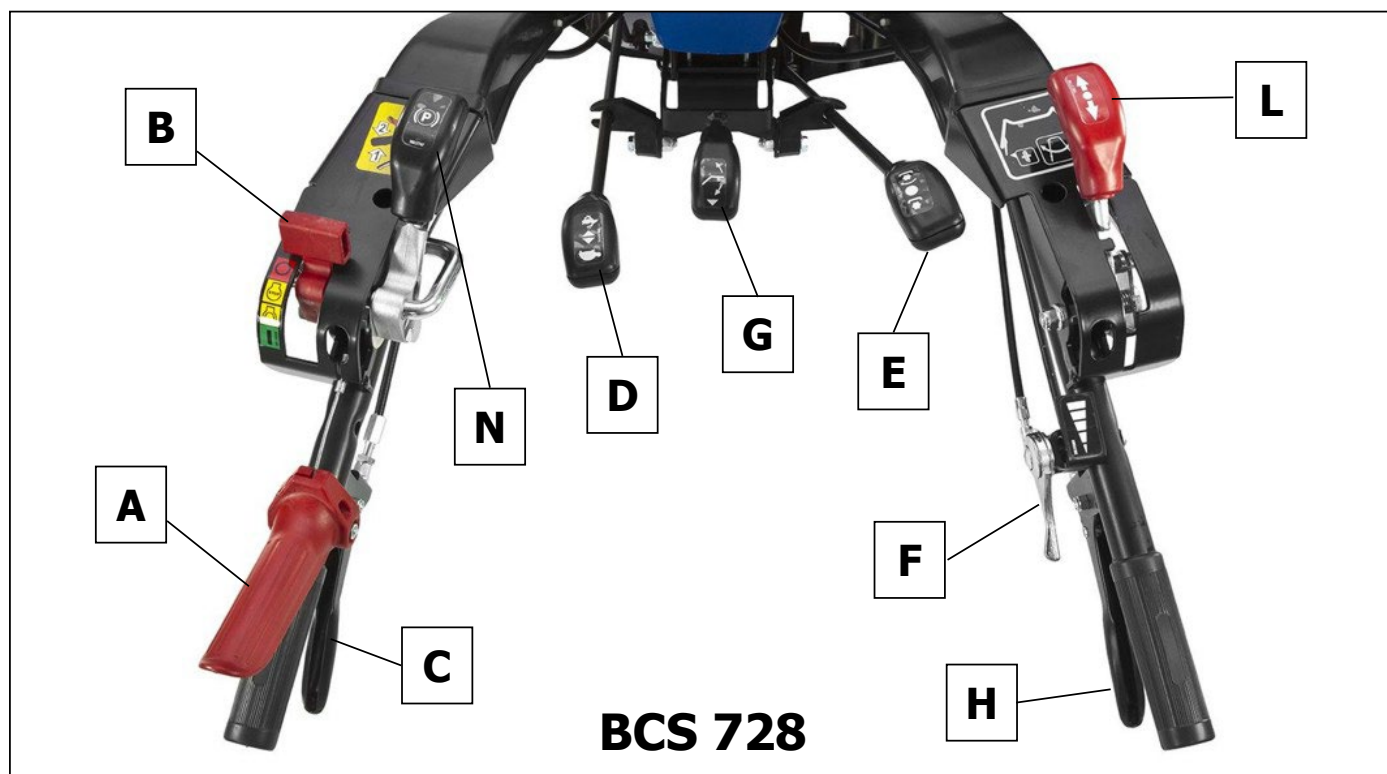
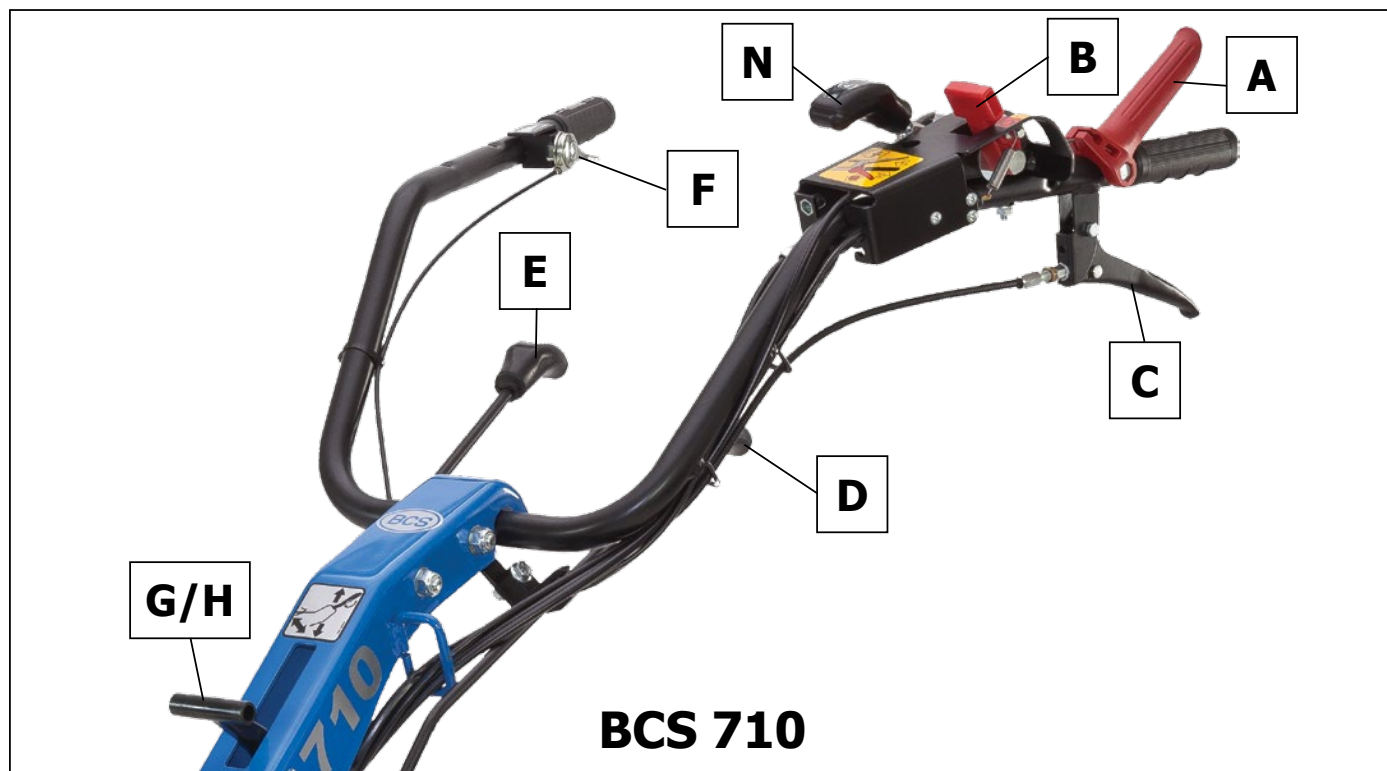

# Controls

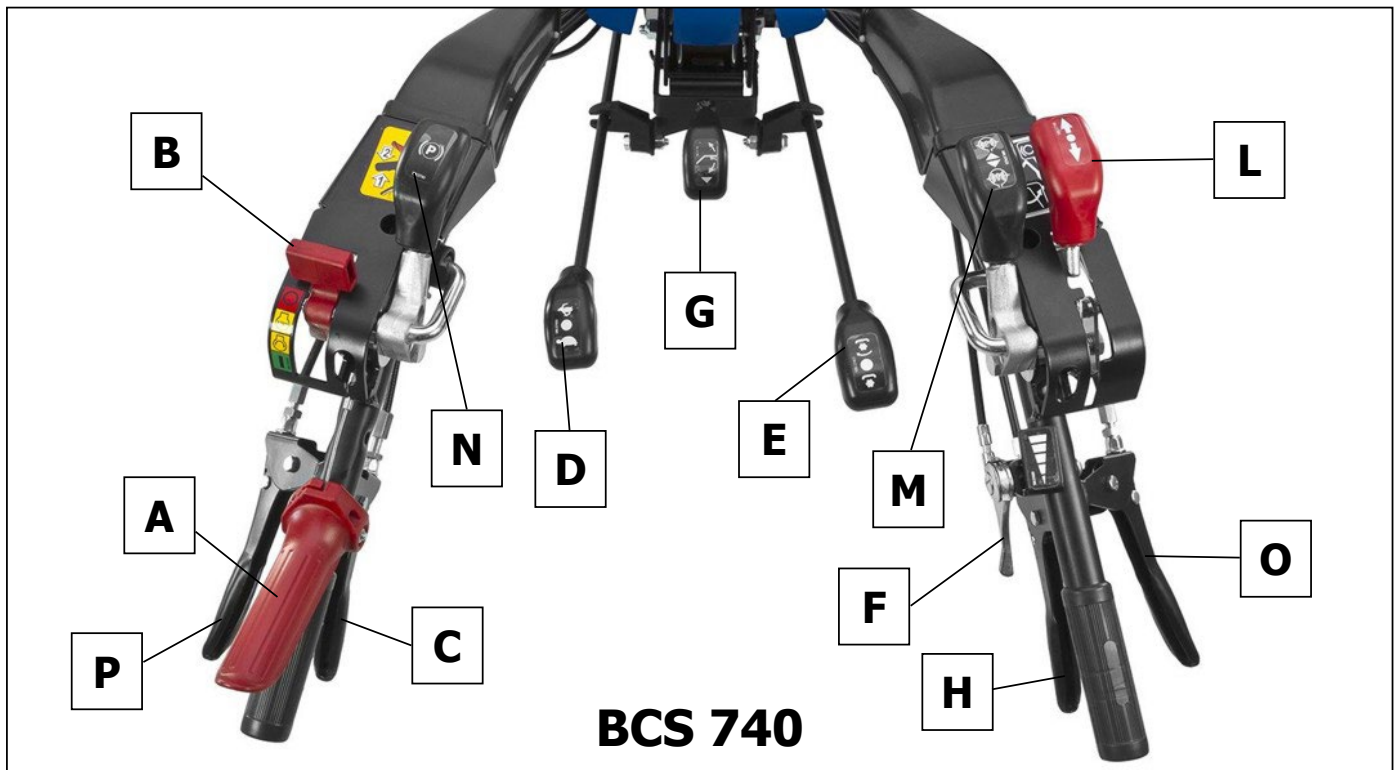
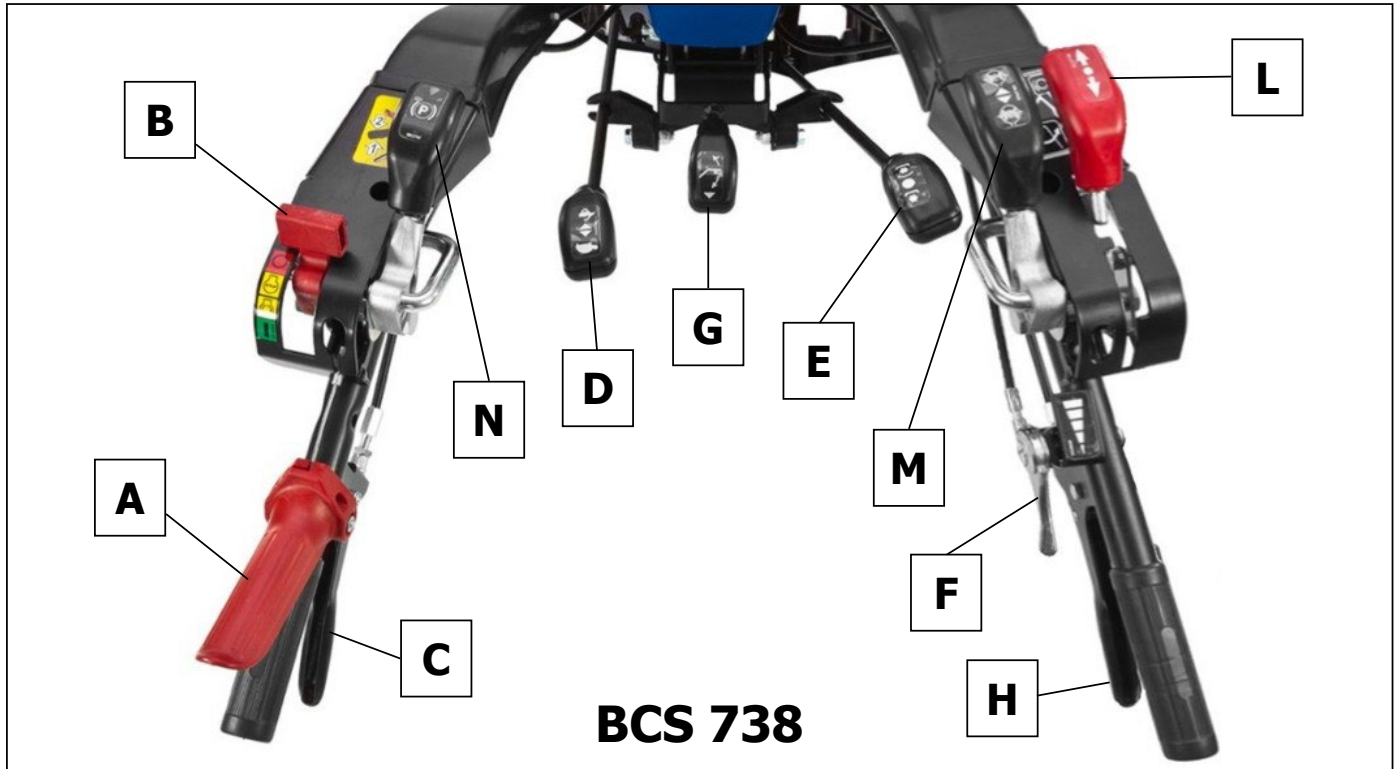

## Controls Description

**SEE PICTURES ON PAGES 2 & 3**

- (A) MACHINE STOP LEVER (red lever that stops the machine when released)
- (B) ENGINE STOP LEVER
- (C) CLUTCH CONTROL LEVER
- (D) GEAR LEVER (the location of different gears are shown on the selector)
- (E) PTO LEVER (there is a safety device that prevents engagement with reverse gear)
- (F) THROTTLE LEVER
- (G) HANDLEBAR HEIGHT ADJUSTMENT LEVER
- (H) STEERING COLUMN SWIVEL LEVER
- (L) FORWARD/REVERSE LEVER (always engage the clutch before engaging this lever)
- (M) DIFFERENTIAL LOCK LEVER
- (N) PARKING BRAKE LEVER
- (O) RIGHT BRAKE LEVER
- (P) LEFT BRAKE LEVER

## Assembly Instructions

1. Remove the machine from its packing case.
2. Rotate the handlebar stem to the operating position and fit the handlebars - check operation and routing of cables.
3. Fit the wheels, ensuring the correct rotation (see diagram A below) and check the tyre pressures (20psi).
4. Fit the gearbox dipstick.
5. Assemble the rear flap on the digging unit ensuring the sticker labels are on the outside (see diagram B below) and attach the unit to the machine.
6. Check the engine oil level.
7. Follow the instructions in this Owner's Manual to run the machine.

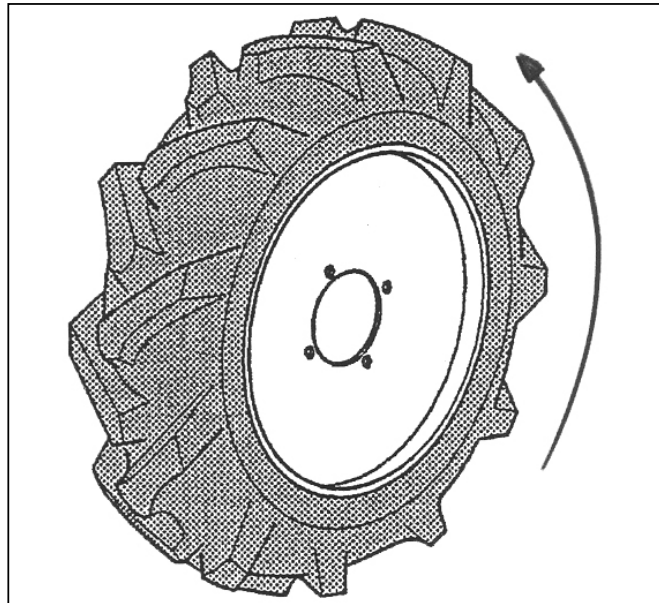

### To Start Petrol Engine

Using the dipstick provided, check the engine oil level. Top up with 10w/40 oil if necessary.

Check fuel level. Only use unleaded petrol from a clean container. Never re-fuel when the engine is hot or running. Leave 1" air space in the fuel tank.

Turn the fuel tap to 'ON' position, if the engine is cold set the choke lever to 'ON' position.

Before starting the engine ensure the gear lever (D) is in neutral position and the power take-off (PTO) lever is disengaged (E).

Apply half throttle (F).

Move the engine stop lever (B) to position 1 'ON'.

Pull the recoil start handle gently until it engages then give it a good strong pull to start the engine.

When the engine has started, release the choke lever after a few seconds and return the throttle lever (F) to idle position.

### To Start Diesel Engine

Using the dipstick provided, check the engine oil level. Top up with 10w/40 oil if necessary.

Check fuel level. Only use diesel from a clean container. Never re-fuel when the engine is hot or running.

Before starting the engine ensure the gear lever (D) is in neutral position and the power take-off (PTO) lever is disengaged (E).

Apply  $\frac{3}{4}$  throttle (F).

Move the engine stop lever (B) to position 1 'ON'.

Press and hold the decompression lever on top of the engine.

Pull recoil start handle gently until it engages then, keeping the decompression lever depressed, slowly pull the engine over 2-3 times to prime the engine.

Release the decompression lever and gently pull over the engine until compression is felt.

Press, but do not hold, the decompression lever and give the starter handle a good strong pull to start the engine.

Once the engine has started return the throttle lever (F) to idle position.



## Operation

Use handlebar adjuster (G) to set handlebar height.

Hold the handlebar and pull up the clutch lever (C).

Depress the red stop lever (A) and select the correct working speed using the gear lever (D).

Ensure forward/reverse lever is in the correct position to move forward (L):

If the handlebars are positioned over the engine then this lever should be in the fully back position.

If the handlebars are positioned over the implement then it should be in the fully forward position.

Engage drive to the working implement by using the PTO lever (E):

If the handlebars are positioned over the engine then pull the PTO lever (E) towards you.

If the handlebars are positioned over the implement then push the PTO lever (E) away from you.

Release clutch lever (C) slowly and fully, keeping the red machine stop lever depressed as the machine will stop if released.

Move the throttle lever to the correct position for the implement you are operating - please refer to the Implement Manual.

Commence work

## To Stop Engine

Close the throttle (F).

Engage clutch lever (C).

Locate gear lever (D) in neutral position.

Disengage drive to the digging knives by pulling the PTO lever (E) backwards.

Release clutch lever (C).

Release the machine stop lever (A) completely.

Move the engine stop lever (B) to position O 'STOP'.

**WARNING: THE EXHAUST COVER MAY BE HOT - DO NOT TOUCH.**

## Maintenance Guide

For engine maintenance please refer to engine manufacturers manual.

After every hour of operation stop the engine and remove the spark plug cap.

Check engine oil level (recommended oil SAE 10w/40).

Replace the spark plug cap.

Do not turn the machine on its side for cleaning.

Before checking the oil level ensure the machine is level.

Remove the gearbox unit dipstick and ensure the oil reaches the top level mark, if necessary top up with API GL-5 80w/90 gear oil (see page 13).

## Maintenance Programme

	<b>OPERATION</b>	<b>EVERY DAY</b>	<b>EVERY WEEK</b>	<b>EVERY MONTH</b>	<b>EVERY 6 MONTHS</b>
<b>ENGINE</b>	Check engine oil level 10w/40 See separate engine manual	X	X		
<b>GEARBOX &amp; CONTROLS</b>	Check gearbox oil level (see page 13)	X	X		
	Check nuts & bolts	X	X		
	Ensure clutch cable has free play		X		
	Check tyre pressure (20psi)		X	X	
	Lubricate control cable/linkages		X		
	Check control cable operation		X		
	Check operation of safety devices		X		
	Change gearbox oil (see page 13)				X
	Grease gear speed detent ball			X	

- \* Pressure washing machines remove lubricating grease as well as dirt. It is imperative all linkages, especially the gear speed lever detent ball, are kept well greased otherwise they will become difficult to operate and cause damage.
- \* DO NOT allow maximum engine speed to exceed 3600rpm.

## Service Information

### Every Week

- With the machine on a level surface, check the gearbox oil level, top up as necessary using the correct oil as listed below. The gearbox oil level should reach between the two notches on the dipstick (*fig. 2, C*).

### After the First 2 Weeks or 30 Hours of Work

- Replace the gearbox **oil filter ONLY**, (*fig. 1, A*), part number 58056249.
- Check the gearbox oil level using the dipstick (*figs. 1 & 2, C*), run the machine for 2-3 minutes and recheck gearbox oil level, top up as necessary using the correct oil as listed below.

### Every 100 Hours of Work or 12 Months

- Change the gearbox oil by removing the gearbox drain plug (*fig. 3, B*).
- Replace the gearbox oil filter (*fig. 1, A*), part number 58056249.
- Clean the gearbox drain plug and refit.
- Fill gearbox using the correct oil and quantity as listed below.
- Check the gearbox oil level, run the machine for 2-3 minutes and recheck gearbox oil level.

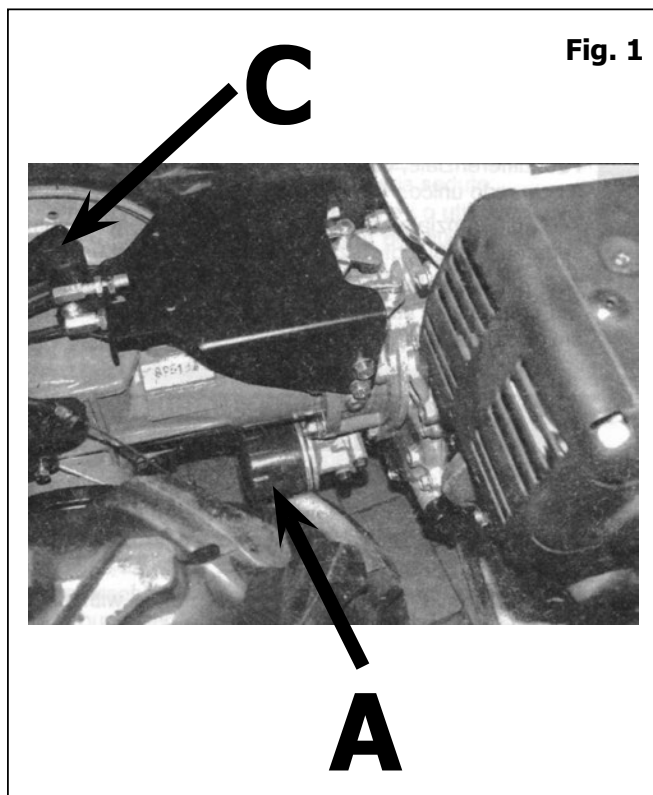

#### To replace the oil filter (**fig. 1, A**)

1. Using the correct spanner, remove the filter.
2. Smear a film of oil on the rubber gasket of the new filter.
3. Mount the new filter, screwing and tightening by hand only.

## Service Information

### Gearbox Oil Quantities

BCS 710 / 728 / 738 = approx 2.3 litres

BCS 740 = approx 2.6 litres

### Oil Type

Fuchs	Titan Hyp 90
Valvoline	80w-90 GL-5
Morris	EP80w/90 API GL5
Castrol	EPX 80w-90
Motorex	Hypoid SAE 80w/90 API GL5
Millers	Hypoid 80w90 GL5
Comma	EP80w-90 GL5
Agip	Rotra MP 80w-90
Rock Oil	SD API GL5 80w/90

Alternatively any oil meeting API GL-5 80w/90 specification may be used.

Multigrade engine oil must **NOT** be used.

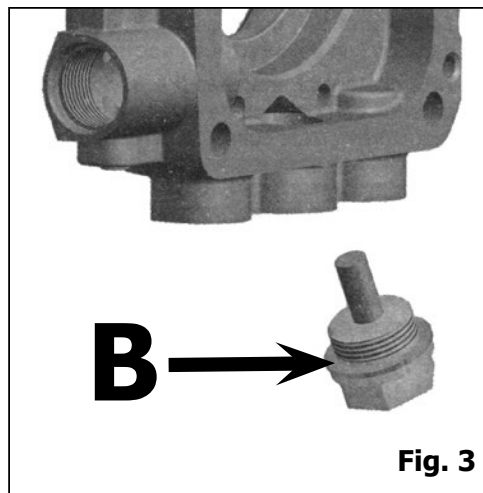
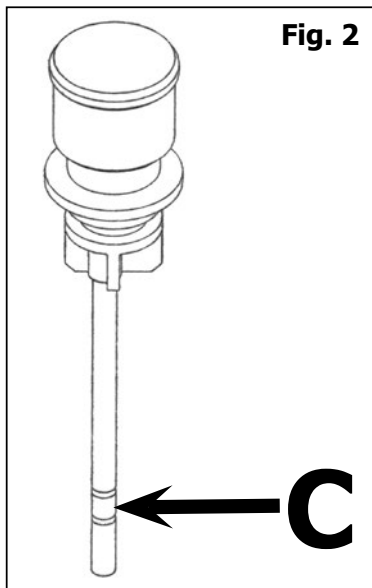

## Troubleshooting Guide

<b>PROBLEM</b>	<b>POSSIBLE CAUSE</b>	<b>REMEDY</b>
Unable to select gear	Pressure washing has removed lubrication of gear lever detent ball.	Grease the detent ball and quadrant.
Unable to pull engine over	Machine has been tipped on side for cleaning and engine oil has filled the cylinder bore causing a hydraulic lock.	Remove spark plug and air filter. Stand to one side and pull over engine to clean out oil. Change engine oil and air filter. Clean spark plug.
No drive to wheels or working implement	Check gearbox oil level.	Top up if necessary with API GL-5 80w/90 oil (see page 13).
Engine smokes	There may be petrol in the engine oil due to fuel tap being left on during transportation.	Change engine oil.
	Contaminated air filter.	Replace element.

## Risk Assessment

HAZARDS	RISK LEVEL	ACTION NEEDED
General		The machine should only be used by trained operators.
Machine tipping over	Low	Do not use on slopes over 25°.
Machine running away	Low	Red stop lever disengages the drive to the implement if the operator releases the handlebars. Always check operation before use.
Lacerations	Medium	Remove the spark plug cap before carrying out any maintenance or cleaning. Always wear gloves when cleaning the working implement or removing debris.
Machine reversing and jamming operator against immovable object	High	Never reverse the machine with your back to a wall or similar object.
Burns	High	Be very careful of a hot exhaust. Turn off the machine before refuelling. Allow 1" air space in the fuel tank.
Handlebar adjustment	Low	Always set the height and sideways position before operating the machine - never while it is moving.

## Service Record

To ensure your machine is kept in peak condition, we recommend that you have it serviced regularly by one of Tracmaster's Authorised Agents.

To find out who your local Authorised Agent is, contact Tracmaster on 01444 247689.

### SERVICE SCHEDULE

#### First 2 Weeks or 30 Hours of Work - whichever is sooner (see page 13)

First PowerSafe® oil filter replacement (part number 58056249)

Check and/or restore gearbox oil level (API GL-5 80w90 specification)

**Signed:**

**Date:**

#### Every 12 Months or 100 Hours - whichever is sooner (see page 13)

Implement transmission oil replacement (API GL-5 80w90 specification)

Engine oil replacement (SAE 15w/40)

**Signed:**

**Date:**

#### 24 Months or 200 Hours

**Signed:**

**Date:**

#### 36 Months or 300 Hours

**Signed:**

**Date:**

#### 48 Months or 400 Hours

**Signed:**

**Date:**

#### 60 Months or 500 Hours

**Signed:**

**Date:**

#### 72 Months or 600 Hours

**Signed:**

**Date:**

#### 84 Months or 700 Hours

**Signed:**

**Date:**

#### 96 Months or 800 Hours

**Signed:**

**Date:**

#### 108 Months or 900 Hours

**Signed:**

**Date:**



# Warranty Registration

To validate your warranty please complete the form below and return it to:

**Tracmaster Ltd, Sovereign Centre, Victoria Road, Burgess Hill, RH15 9LR**

Alternatively visit [www.tracmaster.co.uk](http://www.tracmaster.co.uk) and complete the online form.

## CUSTOMER DETAILS

Name: .....

Company (if applicable): .....

Address: .....

.....

Postcode: .....

Email: .....

Phone: .....



## MACHINE DETAILS

Machine: BCS TWO WHEEL TRACTOR

Model Number: .....

Serial Number: .....

Engine Serial Number: .....

Purchase Date: .....

## SUPPLIER DETAILS (if not supplied directly by Tracmaster)

Dealer Name: .....

Dealer Address: .....

.....

Postcode: .....

We will never pass your details to any third party, however, we may occasionally send you emails with offers and promotions, if you do not want us to do this please tick this box.

**Register your warranty online now!**

**[www.tracmaster.co.uk](http://www.tracmaster.co.uk)**

- **Complete the online warranty form.**
- **View and download spare parts diagrams.**
- **View and download owners manuals and operating instructions.**
- **See working video clips of machines from our BCS and CAMON ranges.**



**T: 01444 247689**



## **IMPORTANT**

**READ THE OWNER'S MANUAL  
FOR THE RELEVANT  
WORKING IMPLEMENT.**

**PLEASE CONTACT TRACMASTER  
ON 01444 247689 FOR  
ANY FURTHER INFORMATION  
OR ASSISTANCE OR VISIT  
[WWW.TRACMASTER.CO.UK](http://WWW.TRACMASTER.CO.UK)**

© Tracmaster Ltd 2013.  
Specifications are subject to change without prior notice.



Tracmaster Ltd, Sovereign Centre, Victoria Road, Burgess Hill RH15 9LR  
T: +44 (0) 1444 247689 F: +44 (0) 1444 871612  
W: [www.tracmaster.co.uk](http://www.tracmaster.co.uk) E: [info@tracmaster.co.uk](mailto:info@tracmaster.co.uk)

TW/T/PJ/0413